

- Generates MIL-PRF-19500 test waveforms
- Amplitude to ± 30 Volts (40 Volts optional)
- Pulse width 0.2 to 20 μ s
- Rise times less than 1.5 ns (10%-90%)
- IEEE-488.2 GPIB and RS-232 interfaces
- Ethernet port for VXI-11.3 support

The AVR-D2 series is specifically designed to perform MIL-PRF-19500 switching time tests of high-speed switching transistors.

The main output (channel A) provides amplitudes of ± 6 V to ± 30 V (optionally ± 40 V) with a pulse width adjustable from 200 ns to 20 μ s. A DC offset of 0 to ± 15 V is available on this output.

A second output (channel B) provides a ± 2 V, 15 ns wide pulse. A DC offset of 0 to ± 1 V is available on this output.

The rise times for both outputs are less than 1.5 ns (10%-90%). The CH A fall time is 2 ns or less, and the CH B fall time is 2.5 ns or less (90%-10%). Both outputs have 50 Ω source impedance. Both outputs are intended to drive 50 Ω load impedances. Only one of the two outputs is active at a time. A 1.0 ns (10%-90%) rise time option is available for the CH A output (30V units only).

Standard models provide the output waveforms on a front-panel BNC connector, and the user is responsible for assembling a suitable test jig with the necessary matching circuitry (usually specified in the military "slash sheet" and socketing. Avtech can provide suitable test jigs with high-speed sockets. If you require such a test jig, contact Avtech (info@avtechpulse.com) with the slash sheet number, the DUT part numbers, and details of the DUT packaging.

The AVR-D2-B includes a complete computer control interface (see <http://www.avtechpulse.com/gpib> for details). This provides GPIB and RS-232 computer-control, as well

as front panel keypad and adjust knob control of the output pulse parameters. A large back-lit LCD displays the output amplitude, polarity, frequency, pulse width, and delay. To allow easy integration into automated test systems, the programming command set is based on the SCPI standard, and LabView drivers are available for download at <http://www.avtechpulse.com/labview>.

A standard rear-panel Ethernet connector allows the instrument to be remotely controlled using the VXI-11.3, ssh, telnet, and web protocols. In particular, the VXI-11.3 features allows software like LabView to control an instrument using standard VISA communications drivers and network cabling, instead of using older-style GPIB cabling and GPIB controller cards. For additional details, please see <http://www.avtechpulse.com/options/vxi>.

The AVR-D2-B requires 100-240V, 50-60 Hz prime power.

A related model, the AVR-D3-B, is available for testing high-current transistors (with amplitudes up to 250V and 5 Amps). For details, please see:

<http://www.avtechpulse.com/semiconductor/avr-d3>

These models can be customized readily to meet special test requirements.

Avtech also offers a variety of pulse generators for use in recovery time tests (forward and reverse), dV/dt tests, and common mode transient immunity tests. For more information, please visit:

<http://www.avtechpulse.com/semiconductor>



AVR-D2-B

Model:	AVR-D2-B ¹	
Output:	CH A	CH B
Amplitude (into 50 Ohms):	6 to 30 V, adjustable ² . + or -, switchable	2 V, fixed. + or -, switchable
DC offset:	-15V to +15V, adjustable	-1V to +1V, adjustable
Pulse width (FWHM):	200 ns to 20 us, adjustable	15 ns, fixed
Duty cycle:	1% maximum	N/A
Rise time of leading edge (10%-90%):	≤ 1.5 ns (≤ 1.0 ns optional ³)	≤ 1.5 ns
Fall time of trailing edge (90%-10%):	≤ 2.0 ns	≤ 2.5 ns
Pulse repetition frequency (PRF):	5 Hz - 50 kHz	
Source impedance:	50 Ohms	
Required load impedance:	50 Ohms	
GPIB and RS-232 control ² :	Standard on -B units.	
LabView Drivers:	Check http://www.avtechpulse.com/labview for availability and downloads	
Ethernet port, for remote control using VXI-11.3, ssh, telnet, & web:	Included. Recommended as a modern alternative to GPIB / RS-232. See http://www.avtechpulse.com/options/vxi for details.	
Settings resolution:	The resolution of the timing parameters (pulse width, delay, period) varies, but is always better than 0.15% of (set value + 20 ns). The amplitude resolution is < 0.1% of the maximum amplitude.	
Settings accuracy:	Typically ± 3% (± 1 ns or ± 2% of max. amplitude) after 10 minute warmup. For high-accuracy applications requiring traceable calibration, verify the output with a calibrated oscilloscope ⁴ .	
Jitter:	± 35 ps ± 0.015% of sync delay	
Trigger modes:	Internal trigger, external trigger (TTL level pulse, > 50 ns, 1 kΩ input impedance), front-panel "Single Pulse" pushbutton, or single pulse trigger via computer command.	
Variable delay:	Sync to main out: 0 to 1.0 seconds, for all trigger modes (including external trigger).	
Sync output:	> +3 Volts, > 50 ns, will drive 50 Ohm loads	
Monitor output:	Provides a 20 dB attenuated coincident replica of main output	
Connectors:	BNC	
Power required:	100-240 Volts, 50-60 Hz	
Dimensions, temperature range:	100 x 430 x 375 mm (3.9 x 17 x 14.8"), +5°C to +40°C	

- 1) -B suffix indicates IEEE-488.2 GPIB and RS-232 control of amplitude, pulse width, PRF and delay. (See <http://www.avtechpulse.com/gpib>).
- 2) The maximum amplitude may be increased from 30V to 40V by specifying the -SOA option.
- 3) Add the -TRF suffix to the model number to specify the ≤ 1.0 ns rise time option. Not available with the -SOA option.
- 4) These instruments are provided with a basic calibration checksheet, showing a

selection of measured output parameters. These measurements are performed with equipment that is calibrated on a regular basis by a third-party ISO/IEC 17025:2005 accredited calibration laboratory. However, Avtech itself does not claim any accreditation. For applications requiring traceable performance, use a calibrated measurement system rather than relying on the accuracy of the pulse generator settings.

The AVR-D2 series can be used to generate the input pulses for common transistor switching time tests specified in MIL-PRF-19500 slash sheets, like these examples:

MIL-PRF-19500/177F FIG 2. Nonsaturated switching time test circuit.

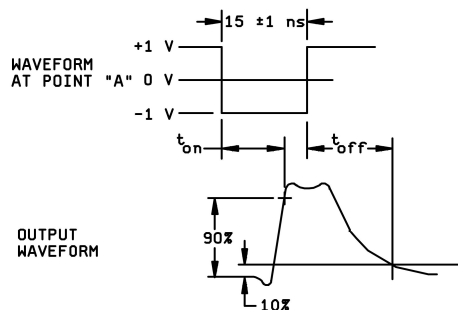
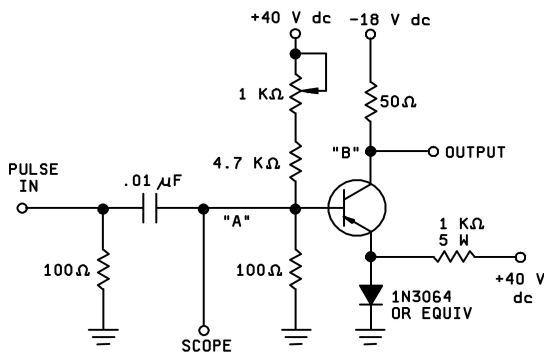

Singapore Main Office
 Telephone: +65 6996 0391
 Email: info@simtrum.com

China Main Office
 Telephone: +86 15000853620
 Email: sales@simtrum.cn

MIL-PRF-19500/255V

FIG 18. Saturated turn-off switching time test circuit.

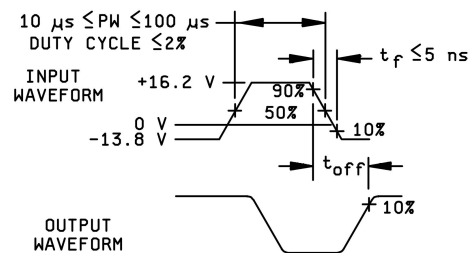
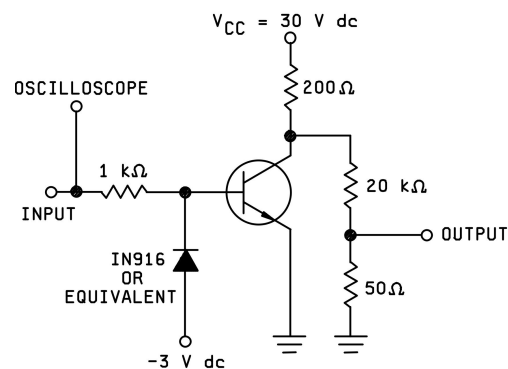

SIMTRUM
www.simtrum.com